

Selection Guidelines

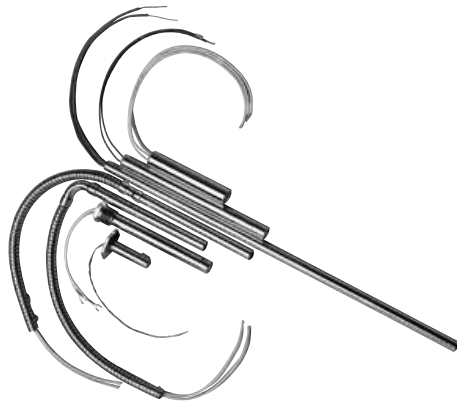

Type CIR
High Watt Density

Advanced Internal Construction Plus Swaged Leads — The challenge to Chromalox engineers was to design a cartridge heater that would out perform any brand cartridge heater — under any given set of conditions, and to assure that the customer receives and continues to receive the most heater performance and life possible for his investment.

Type CIR Cartridge Heater — Includes several significant advances in cartridge heater technology. Its high performance characteristics have been proven, not only in the laboratory, but also on Customers' equipment on selected problem applications, at 1500°F and higher operating temperatures.

Type C-LD, C-HD & C-DE
Medium Watt Density

Type C Large Diameter Cartridge Heater — For medium and low watt density applications. The tightly compacted refractory insulation provides excellent heat transfer to the heavy wall stainless steel sheath. This means the resistance wire runs at a lower temperature than competitive units with loose-fill insulation; the result is much longer life. This heavy-duty construction also provides high dielectric strength as well as shock and vibration resistance required for many industrial applications.

Type CBH Electric Stud Heater — Used to wrench-tighten bolts or studs to “shrink fit” tightness.

Type SCB Small Space Heater — Edison screw base installs in standard porcelain lamp socket to heat very small spaces.

Cartridge Heaters — Selection Guidelines

Model	Applications	Max. Work Temp. (°F)	Watts	Dimensions (In.)		Sheath Material	Sheath Temp. (°F)	Terminal Type	Life Rating	Page
				Length	Dia.					
CIR CIRM	Molds, Dies, Platens, Hot Plates, Sealing	1400	75 - 5,000	1 - 60	1/8 to 1-1/4	INCOLOY® & Stainless Steel	1500	Swaged Leads	Superior	A-117
SST QST	Molds, Dies Platens, Presses	1400	Variable	5 to 60 5 to 36	3/8 to 1	INCOLOY®	1600	Flexible Leads	Standard	A-129
C-HD	Dies, Container	600	140 - 1,780	Up to 24	15/16, 1, 1-19/64	Brass		Two Bolt Terminals	Superior	A-125
MZ	Hot Press Metal Forming, Zone Control	1800	Variable	18 to 180	.495, .685 .935	INCONEL® 600	1800	Plug	Standard	A-126
CBH ¹	Shrink Tightening	1200	1,150 - 11,500	18 to 60	.553-1.106	Steel	1600	Standard Octagon Box with Handle	Standard	A-132
SCB	Closet and Control Cabinet Space Heating	600	50 - 200	4-3/4	1-3/8	Brass	1000	Edison Screw Base (light bulb socket)	Standard	A-130
HTRC	Heat Transfer and Release Coating	1800					<750			A-116
C-DD	Medical, Analytical, Aerospace, Transportation	1400	25-3000	1-10	1/8" - 3/4"	304/316SS	1500	Swaged Leads Pins	Superior	A-124
CTRH	Forming, Dies, Platens	800	1,670 - 5,130	Up to 66"	.553 - .663	Stainless Steel			Superior	A-131

Note —

1. Not UL Recognized or CSA Certified.





Cartridge Heaters

Application & Installation Recommendations

Applications

Application at High Watt Densities —

Type CIR & CIRM cartridge heaters are designed and manufactured to provide watt density capabilities second to none. To obtain best life at the highest watt densities allowed per Curve G-235 in the Application Guidelines, close attention to application details is suggested.

- A. For closest fit and best heat transfer, holes should be drilled and reamed, rather than just drilled to final diameter with a general-purpose drill.
- B. The sensor for the temperature control should be placed between the working surface of the part and the heaters. The temperature of the part approximately 1/2" away from the heaters is used in selecting maximum allowable watt density from the graph.
- C. Control of power is an important consideration in high watt density applications. On/Off control is frequently utilized, but it can cause wide excursions in the temperature of the heater and working parts. SCR power controls are valuable in extending the life of high watt density heaters, since they effectively eliminate on-off cycling.

Application at Medium Watt Densities

— Curve G-235 in the Application Guidelines shows maximum allowable watt density for various fits and operating temperatures. The vast majority of applications do not require maximum W/In², however. Use a watt density only as high as you need. Take advantage of the safety margin provided by using ratings less than the maximum allowed. Select and space heaters for most even heat pattern rather than for highest possible wattage per heater.

At medium watt densities, general purpose drills are usually adequate for drilling holes. Typically, these result in holes 0.003 to 0.008" over the normal size of the drill, resulting in fits of 0.01 to 0.015". Of course, the tightest fit is desirable from a heat transfer standpoint, but somewhat looser fits aid in installing and removing cartridge heaters, especially long ones. Holes drilled completely through the part are recommended to facilitate removal of the heater. After drilling, clean or degrease the part to remove cutting lubricants.

Operation in Vacuum — When heaters are operated in a block which is in a vacuum, the

inside of the holes should be pre-oxidized to improve emissivity. Substantial reductions in maximum allowable watt density are usually necessary for vacuum operation. Where possible, the installation should be designed so that the lead end of the heater is outside the vacuum. When the lead end of the heater is inside the vacuum, a voltage of 120 volts or less is recommended. On an unsealed heater, outgassing may be expected.

Operation in Square Grooves — Round type CIR & CIRM cartridge heaters may be installed in square or v-shaped grooves if this proves convenient. The inside of the groove should be treated to improve its emissivity (by oxidizing or anodizing). Allowable W/In² can be estimated by using the 0.05" fit line in the graph, providing that the square is approximately the same width as the nominal diameter of the heater.

Operation on 480V — Chromalox type CIR & CIRM cartridge heaters 5/8" diameter and larger can be operated on 480 volts. One approach is to take two stock 240 volt heaters and connect them in series on 480 volts. Another is to order specially rated 480 volt cartridge heaters. Check with your Local Chromalox Sales office for recommendations.

Because of higher voltage stresses inside the heater, lower maximum watt densities are allowable in 480 volt applications, either with two 240 volt heaters in series or with specially rated 480 volt units. To determine maximum allowable watt density at 480 volts, enter Curve G-235 with an operating temperature value which is 200°F higher than the actual operating temperature. A maximum operating temperature of 1000°F is suggested.

Testing Recommendations

Testing Recommendations — Testing under simulated operating conditions is suggested when equipment manufacturers design new products. Cartridge heaters of the appropriate physical size are operated on a variable transformer until the heat output is at the proper level. Then, voltage and current measurements are taken and required wattage rating is calculated. Heaters of the correct wattage rating are then ordered for the designed product.

Installation Recommendations

1. On moving machinery, anchor the leads securely. As little movement as possible should be allowed close to where the leads

emerge from the heater. A loop in the lead wire will frequently extend lead life. If application conditions result in continual lead flexing, terminate the cartridge heater leads at a terminal block which moves with the heated assembly. Flexing is transferred to the extension leads which can be economically replaced.

2. For rapidly vibrating equipment, employ the terminal block described above. Keep leads from heater to block short and well supported to prevent lead movement due to vibration.
3. Protect leads from spray, oil and abrasion. Contaminating liquids and vapors can enter unsealed cartridge heaters and cause insulation breakdown.
4. Avoid tape on leads where they emerge from the cartridge heater. The adhesive on some tapes can enter the heater and turn to carbon which is electrically conductive. Where glass tape cannot be avoided, a tape with a silicone based adhesive is suggested.
5. Design the installation so that the leads are in an ambient temperature which doesn't exceed the rating on the lead insulation (842°F for standard leads). Where temperatures require it, use nickel or nickel-plated copper wire with fluoropolymer insulation, silicone impregnated Fiberglas® or Rockbestos® insulation to extend leads.
6. Graphite and other lubricants to help insert the cartridge heater into the hole are generally not recommended. These are electrically conductive and can get on the lead end of the heater unless extra care is taken. Use Chromalox heat transfer and release coating.
7. As operating temperatures rise, thermal insulation on the heated part becomes more desirable to conserve heat. Thermal insulation results in lower wattage requirements and therefore lower watt density on the heaters. Other benefits are more even work temperatures and greater operator safety and comfort.
8. Leads must not extend into the hole containing the cartridge heater. Generally, the lead end of the heater sheath should be flush with the surface of hole or extended by 1/16 inch.



Cartridge Heaters

Modifications & Options

Modifications & Options

Cartridge heaters can be easily specified to meet the demands of special applications. Simply select from a variety of standard options and features to customize the heater to your specific needs. For customized engineering or alternative options, contact your Chromalox sales representative for fast turnaround on your specifications.

- Leadwire Types
- End Seal Options
- Lead Options
- Mounting Options
- Built-In Thermocouple

Leadwire Types

Description	Volts	Operating Temperature	
		(°F)	(°C)
Mica Fiberglas® Insulation	300V Standard 600V	842	450
Fluoropolymer	300V 600V	392	200

Seal Options

Type	Description/Application
Epoxy	Epoxy seal available on above leads by voiding end of sheath and filling with epoxy to provide a moisture barrier.
Fluoropolymer	A swaged-in seal that provides additional moisture resistance.
RTV	For applications where a moisture barrier is required.
Hermetic	Ceramic-to-metal seal is good for element temperatures up to 1000°F. Specify heater length beyond the seal. Metal portion of the seal overlaps the heater sheath by 3/16".
MR SEOT2	Meets UL File SEOT2.SA 12768

End Seal Temperature Limits

Description	Operating Temperature	
	(°F)	(°C)
Air Set Cement Standard	1000	538
Epoxy Seal	194	90
Fluoropolymer Seal	392	200
RTV Seal	284 392	140 200
Hermetic Seal	1000	538
MR-SEOT2	374	190

End Seal Options

Hermetic Seal

Ceramic-to-metal seal is good for element temperatures up to 1000°F. Specify heater length beyond the seal. Metal portion of the seal overlaps the heater sheath by 3/16". For washdown conditions.

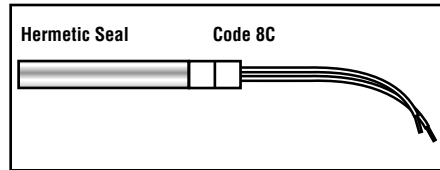

Lead Options

Right Angle Flexible Leads

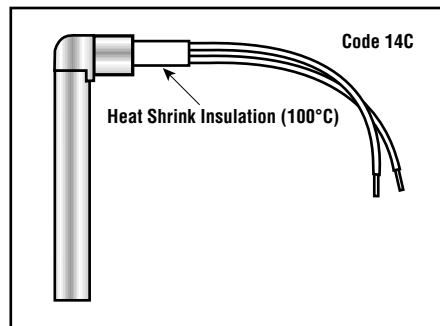

Strain Relief

Strain Relief supports leads to reduce bending, crimping and breakage.

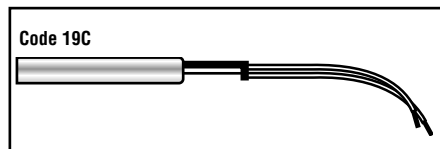

Lead Options (cont'd.)

Flexible Stainless Steel Conduit

Flexible Stainless Steel Conduit provides leadwire protection from abrasion and sharp edges, and facilitates easier handling in harsh environments. Available in both straight and right angle configurations.

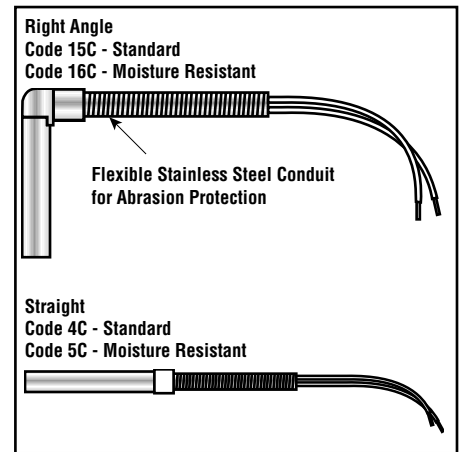

Protective Spring

Available in both straight and right angle configurations, the Protective Spring gives strong, yet flexible leadwire protection from bending, fatigue and flexing.

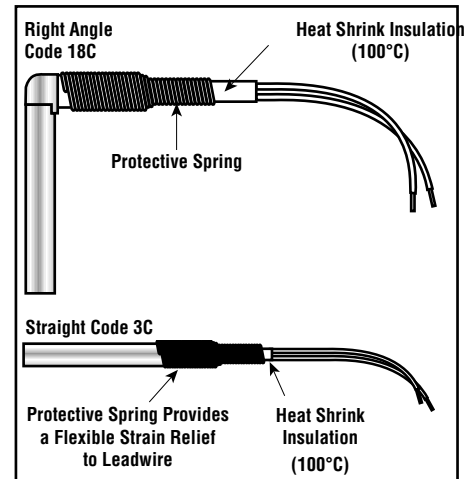

Cartridge Heaters

Modifications & Options *(cont'd.)*

Lead Options *(cont'd.)*

Metal Braid

Stainless Steel metal braid protects leadwire from abrasion and sharp edges, yet maintains flexibility and ease of installation. Metal braid is available in both straight and right angle configurations.

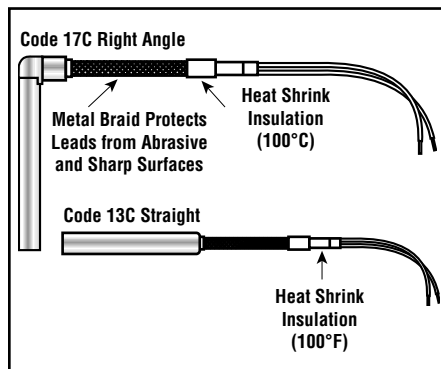

Ceramic Beads

Ceramic Bead insulation can be specified to protect leadwires from high ambient temperatures up to 1200°F (649°C). To order, specify ceramic beads length and additional lead length.

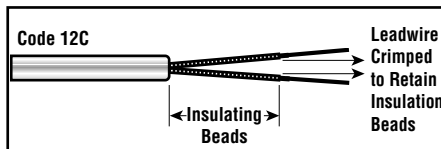

Threaded Post Terminals

Post Terminals provide a strong, secure connection to buss bars or ring/fork connectors. Available only on 5/8 and 3/4" diameter heaters.

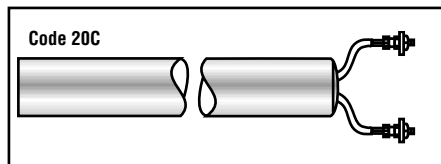

Mounting Options

Threaded Fittings

Threaded fittings allow the heater to be easily installed into a threaded hole for immersion applications. Available with single or double threaded fittings. The fitting overlaps the cartridge heater sheath by 1/4". Specify "brass" or "stainless steel" threaded fitting.

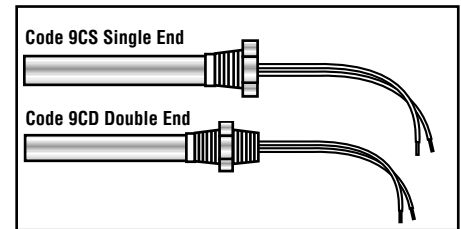

Threaded Fitting Sizes

Nom. Heater Diameter (In.)	NPT Size (In.)	Hex Size (In.)
1/4	1/8 - 27	7/16
3/8	1/4 - 18	9/16
1/2	3/8 - 18	11/16
5/8	1/2 - 14	7/8
3/4	3/4 - 14	1-1/16

Mounting Flange

The mounting flange option allows for easy mounting and specific positioning of the heater within an application.

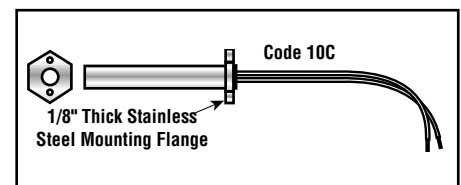

Wire Pull

The Wire Pull assists in heater removal.

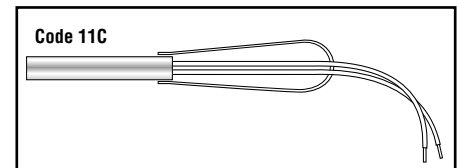



Cartridge Heaters

Thermocouple Leadwire

- Process Temperature Control
- Protection from Overheating and Temperature Burnout
- Type J or K

In some applications, the heating element temperature is closely related to the temperature of the platen or mold it is heating. Chromalox Cartridge heaters with built-in thermocouples allow you to precisely measure the temperature at the ideal measurement point within the cartridge heater, and control the internal heater temperature to more closely maintain the optimum process temperature. Longer heater life and increased heat transfer efficiency may be achieved by precisely controlling the heater temperature.

Built-In Thermocouple Cartridge Heaters are available in three styles, each designed for specific application needs.

Thermocouple Cartridge Styles

Code T1

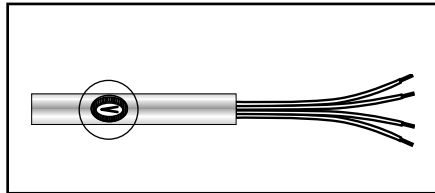

Thermocouple (T/C) junction is located in the center of the core and at any point along the length. The T/C is not grounded. Style T1 is used as an overtemperature control or for burnout protection. It can also be used for process temperature control.

Code T2

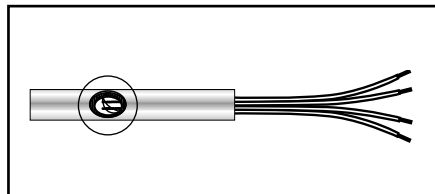

T/C junction is located at most any point (specify location) along the length of the heater and grounded against the sheath. A 1/2" unheated section must be allowed for the T/C to clear the resistance wire.

Style T2 is used to control process temperature. T/C should be placed along the length of the heater in the most suitable position to control the temperature of the mold or platen being heated.

Code T3

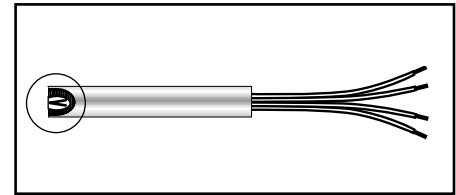

T/C junction is embedded in the end disc. The T/C is grounded.

Style T3 is used when the process temperature at the end of the cartridge heater is critical. In applications where the process product flows past the heater end, such as plastic molding, this thermocouple style allows the cartridge end temperature to be closely controlled.

Thermocouples

Type	Range	
	(°F)	(°C)
Type J	100 - 1400	38 - 760
Type K	100 - 2300	38 - 1260
Diameters	3/8, 1/2, 5/8, 3/4"	
Leadwire Length	Standard 14 inches Maximum length available 36 inches	



HTRC — Chromalox Heat Transfer and Release Coating (Patented)

Chromalox HTRC is used for improving heat transfer and release in the following applications.

- Cartridge units in drilled holes.
- Tubular units in drilled holes, grooves or clamp-on surfaces.
- Strip and Ring heaters in grooves or clamped on to rough surfaces.

Laboratory tests have demonstrated that in high temperature applications, improved heat transfer can lower the internal wire temperature to provide up to 100% improvement in heater life. Chromalox HTRC is recommended for use in the above applications where sheath temperature of the heater is expected to exceed 750°F.

HTRC has an excellent heat transfer coefficient approaching that of aluminum. Shelf life greater than one year.

- PCN 014293 - 4 oz.
- Max. Temp. -1800°F



CARTRIDGE

CIR/CIRM

CIR 1/8" to 1-1/4" dia.
CIRM 6mm to 20mm dia.
Cartridge Heater

- 50 - 5,000 Watts
- Up to 480 Volt
- 1" to 60" Sheath Lengths
- INCOLOY® or Stainless Steel Sheath



Dimensions

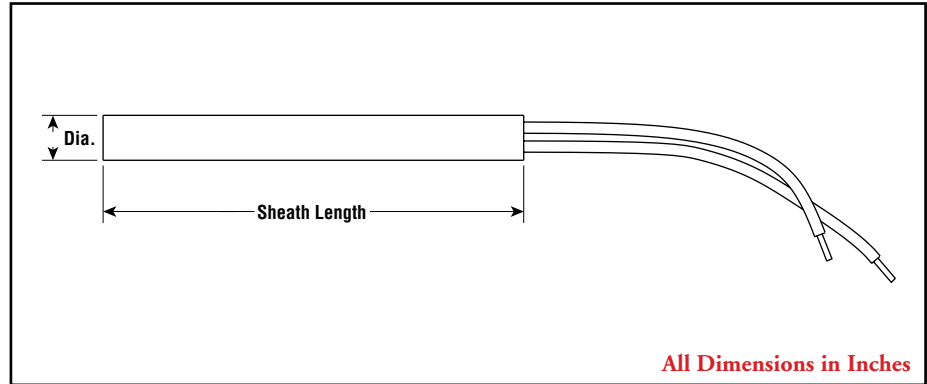

Applications

- Dies and Molds
- Packing Machinery
- Laminating/Adhesives
- Hot Glue Melting
- Lead Melting
- Medical Application
- Extruding Dies
- Stamping and Marking Machine

Features

Leads can be bent at right angle near the heater without exposing bare wire therefore eliminating electrical shorts.

Sheath Material — Type CIR & CIRM cartridge heaters are made with a high-temperature INCOLOY® or stainless steel sheath material.

High Temperature Leadwire — Up to 842°F (450°C).

Lead Length — Type CIR heaters are stocked with 14" long leads. Longer lead lengths can be readily spliced on.

Advantages

Higher Temperatures, Faster Production Rates — Because Type CIR's patented construction and high watt density capability let you put more heat in less space.

Shock and Vibration Resistant — Tightly compacted refractory insulation makes CIR heaters suitable for severe applications.

Even Temperature throughout the heater's length is produced by the uniform winding of the wire on the smooth supporting core. Close and even spacing between wire and inside of sheath is maintained for good heat transfer. Tight spacing between turns permits the use of largest gauge resistance wire.

Excellent Oxidation and Corrosion Resistance is provided by special Chromalox alloy sheath. Thermal expansion characteristics of sheath and refractory are closely matched.

CIR/CIRM

CIR 1/8" to 1-1/4" dia.

CIRM 6mm to 20mm dia.

Cartridge Heater *(cont'd.)*

Cartridge Configurations

1T Teflon leads & cap		8C Strain Relief	
14C Leads Right Angle		3C Protective Spring	
13C Stainless Steel Braid (Straight)		12C Ceramic Beads	
17C Stainless Steel Braid Right Angle		9C S/CD Fittings	
4C Stainless Conduit Straight		10C Flanges	
15C Stainless Conduit Right Angle		11C Wire Pull	
1B Copper Fitting Right Angle		20C Y Terminals	
1C Copper Fitting Right Angle		T1, T2, T3 Thermocouple	

Specifications and Ordering Information

DIM (In.)						120V		240V		Wt. (Lbs.)
Dia.	Sheath Length	Watts	W/In ²	Model	Stock	PCN	Stock	PCN		
1/4" Diameter										
1/4	1-1/4	75	128	CIR-1013	S	279216	—	—	0.02	
1/4	1-1/4	100	171	CIR-1012	S	274255	—	—	0.02	
1/4	1-1/4	150	256	CIR-1014	NS	279224	—	—	0.02	
1/4	1-1/4	225	388	CIR-10121	—	—	S	242050	0.02	
1/4	1-1/2	50	64	CIR-1016	NS	279232	—	—	0.02	
1/4	1-1/2	100	128	CIR-1017	NS	279240	—	—	0.02	
1/4	1-1/2	125	160	CIR-1015	S	274263	—	—	0.02	
1/4	1-1/2	150	192	CIR-1018	NS	279259	—	—	0.02	
1/4	1-1/2	175	220	CIR-1019	NS	279267	NS	279275	0.02	
1/4	1-1/2	200	256	CIR-10151	NS	279283	S	279291	0.02	
1/4	1-1/2	250	290	CIR-10153	—	—	S	283952	0.02	
1/4	1-3/4	100	127	CIR-10181	NS	140396	—	—		
1/4	2	100	85	CIR-1021	S	279304	—	—	0.03	
1/4	2	125	107	CIR-1022	—	279312	NS	279320	0.03	
1/4	2	150	128	CIR-1020	S	274271	S	279339	0.03	
1/4	2	200	171	CIR-1023	NS	279347	S	279355	0.03	
1/4	2	250	214	CIR-1024	NS	279363	S	279371	0.03	
1/4	2	300	256	CIR-10201	—	—	NS	284664	0.03	

Specifications and Ordering Information

DIM (In.)						120V		240V		Wt. (Lbs.)
Dia.	Sheath Length	Watts	W/In ²	Model	Stock	PCN	Stock	PCN		
1/4" Diameter										
1/4	2-1/4	150	127	CIR-10231	S	140409	—	—		
1/4	2-1/4	200	170	CIR-10231	S	140417	—	—		
1/4	2-1/4	80	67	CIR-10231	NS	140425	—	—		
1/4	2-1/2	175	112	CIR-1025	NS	279380	—	242077	0.03	
1/4	2-1/2	200	128	CIR-1027	—	284550	S	283960	0.03	
1/4	2-1/2	250	160	CIR-1029	NS	242085	NS	242093	0.03	
1/4	2-3/4	200	127	CIR-10281	NS	140433	—	—		
1/4	3	100	51	CIR-1031	NS	279400	—	279419	0.04	
1/4	3	150	77	CIR-1034	—	284605	S	283979	0.04	
1/4	3	200	103	CIR-1030	S	274280	S	279427	0.04	
1/4	3	250	129	CIR-10301	—	—	S	284672	0.04	
1/4	3	300	153	CIR-1032	NS	279435	S	279443	0.04	
1/4	3	400	205	CIR-1033	—	—	S	279451	0.04	
1/4	3-1/4	200	102	CIR-10331	S	140441	—	—		
1/4	3-1/2	100	43	CIR-1035	—	279460	—	279478	0.04	
1/4	3-1/2	200	85	CIR-1036	—	279486	—	279494	0.04	
1/4	3-1/2	225	96	CIR-1038	—	—	—	285421	0.04	
1/4	3-1/2	300	127	CIR-1037	—	—	S	284699	0.04	

CIR/CIRM

CIR 1/8" to 1-1/4" dia. & CIRM 6mm to 20mm dia. Cartridge Heater (cont'd.)

CIR Cartridge Design Guide											
Diameter	Size	Code	1/8"	1/4"	5/16"	3/8"	1/2"	5/8"	3/4"	1"	1-1/4"
	Decimal		.121+/- .002	.246+/- .002	.308+/- .002	.371+/- .002	.496+/- .002	.621+/- .002	.746+/- .002	.996+/- .002	1.246+/- .002
Length	Tolerance		+/-3%*	+/-2%*	+/-2%*	+/-2%*	+/-2%*	+/-2%*	+/-2%*	+/-2%*	+/-2%*
Sheath	Incoloy		X	X	X	X	X	X	X	N/A	N/A
	304SS		N/A	N/A	X	X	X	X	X	X	X
Terminations	Leads	MGT	X	X	X	X	X	X	X	X	X
	Leads	PTFE	X	X	X	X	X	X	X	X	X
	Pins		N/A	X	N/A	X	X	X	X	X	X
Seals	Epoxy		X	X	X	X	X	X	X	X	X
	Silicone		NA	X	X	X	X	X	X	X	X
	Cement		X	X	X	X	X	X	X	X	X
	Hermetic Seal	8C	N/A	N/A	N/A	X	X	X	X	N/A	N/A
Configurations	Teflon (leads & cap)	1T	NA	X	X	X	X	X	X	NA	NA
	Leads RA	14C	N/A	X	X	X	X	X	X	X	X
	Braid Straight	13C	X	X	X	X	X	X	X	X	X
	Braid RA	17C	N/A	X	X	X	X	X	X	X	X
	Conduit Straight	4C	N/A	X	X	X	X	X	X	X	X
	Conduit RA	15C/16C	N/A	X	X	X	X	X	X	X	X
	Copper Straight	1B	N/A	X	N/A	X	X	X	X	N/A	N/A
	Copper RA	1C	N/A	X	N/A	X	X	X	X	N/A	N/A
	Strain Relief	19C	N/A	X	X	X	X	X	X	X	X
	Protective Spring	3C	N/A	X	N/A	X	X	X	X	N/A	N/A
	Ceramic Beads	12C	N/A	X	X	X	X	X	X	X	X
	Fittings	9CS/CD	N/A	X	X	X	X	X	X	X	X
	Flanges	10C	X	X	X	X	X	X	X	X	X
	Wire Pull	11C	N/A	X	X	X	X	X	X	N/A	N/A
	Y Terminals	20C	N/A	N/A	N/A	N/A	N/A	X	X	X	X
	Thermocouple	T1	**	X	X	X	X	X	X	X	X
	Thermocouple	T2	**	X	X	X	X	X	X	X	X
	Thermocouple	T3	**	X	X	X	X	X	X	X	X

*Length tolerance is either +/- % or 3/32" whichever is greater

**Only available at lead end of heater

CIRM Metric Cartridge Design Guide										
Diameter	Size		6mm	6.5mm	8mm	10mm	12mm	12.5mm	16mm	20mm
	Decimal		.234+/- .002	.254+/- .002	.313+/- .002	.392+/- .002	.470+/- .002	.490+/- .002	.628+/- .002	.785+/- .002
Length	Tolerance		+/-2%*	+/-2%*	+/-2%*	+/-2%*	+/-2%*	+/-2%*	+/-2%*	+/-2%*
Sheath	Incoloy		X	X	X	X	X	X	X	N/A
	304SS		N/A	N/A	X	X	X	X	X	X
Terminations	Leads	MGT	X	X	X	X	X	X	X	X
	Leads	PTFE	X	X	X	X	X	X	X	X
	Pins		X	X	N/A	X	X	X	X	N/A
Seals	Epoxy		X	X	X	X	X	X	X	X
	Silicone		X	X	X	X	X	X	X	X
	Hermetic Seal	8C	N/A	X	N/A	N/A	N/A	X	N/A	N/A
	Cement		X	X	X	X	X	X	X	X
Configurations	Teflon (leads & cap)	1T	N/A	X	N/A	X	N/A	X	N/A	N/A
	Leads RA	14C	X	X	X	X	X	X	X	X
	Braid Straight	13C	X	X	X	X	X	X	X	X
	Braid RA	17C	X	X	X	X	X	X	X	X
	Conduit Straight	4C	X	X	X	X	X	X	X	X
	Conduit RA	15C/16C	X	X	X	X	X	X	X	X
	Strain Relief	19C	X	X	X	X	X	X	X	X
	Protective Spring	3C	N/A	N/A	N/A	N/A	N/A	N/A	N/A	N/A
	Ceramic Beads	12C	X	X	X	X	X	X	X	X
	Fittings	9CS/CD	X	X	X	X	X	X	X	X
	Flanges	10C	X	X	X	X	X	X	X	X
	Wire Pull	11C	X	X	X	X	X	X	X	X
	Y Terminals	20C	N/A	N/A	N/A	N/A	N/A	N/A	X	X
	Thermocouple	T1	X	X	X	X	X	X	X	X
	Thermocouple	T2	X	X	X	X	X	X	X	X
	Thermocouple	T3	X	X	X	X	X	X	X	X

*Length tolerance is either +/- % or 2.5 mm whichever is greater

**Not available with fittings or flanges

CIR 1/4 - 3/4" Dia. Cartridge Heater (cont'd.)

Specifications and Ordering Information

DIM (In.)		Watts	W/in ²	Model	120V		240V		Wt. (Lbs.)
Dia.	Sheath Length				Stock	PCN	Stock	PCN	
1/2" Diameter									
3/4	5	300	28	CIR-5052	S	244460	—	—	0.39
3/4	5	500	47	CIR-5051	—	—	S	281084	0.39
3/4	5	1,000	95	CIR-5050	NS	278070	NS	278088	0.39
3/4	6	350	27	CIR-5061	S	140281	S	275813	0.48
3/4	6	500	39	CIR-5065	S	244478	S	244486	0.48
3/4	6	750	58	CIR-5062	—	—	—	281092	0.48
3/4	6	1,000	78	CIR-5067	—	—	S	244494	0.48
3/4	6	1,100	85	CIR-5060	NS	278096	S	278109	0.48
3/4	6	1,500	117	CIR-5068	—	—	—	244507	0.48
3/4	6	2,000	155	CIR-5069	—	—	S	244515	0.48
3/4	7	500	33	CIR-5075	S	244523	—	244531	0.57
3/4	7	1,000	66	CIR-5072	—	—	S	244540	0.57
3/4	7-5/8	450	27	CIR-5077	S	140290	S	275821	0.61
3/4	7-5/8	1,300	78	CIR-5076	—	278117	S	278125	0.61
3/4	8	500	28	CIR-5085	NS	244558	NS	244566	0.64
3/4	8	1,000	57	CIR-5080	—	—	S	281105	0.64
3/4	8	1,500	85	CIR-5081	—	—	—	281113	0.64
3/4	8	2,000	113	CIR-5082	—	—	S	281121	0.64
3/4	9-1/8	500	25	CIR-5091	NS	140302	S	275830	0.73
3/4	10	1,000	45	CIR-5100	—	—	S	281130	0.79
3/4	10	2,000	90	CIR-5102	—	—	S	244574	0.79
3/4	10-1/2	550	23	CIR-5106	NS	140310	NS	275848	0.83
3/4	10-1/2	2,000	85	CIR-5105	S	278133	S	278141	0.83
3/4	11-7/8	600	22	CIR-5118	NS	140329	S	275856	0.91
3/4	12	1,000	37	CIR-5120	—	—	S	281148	0.92
3/4	12	2,000	74	CIR-5121	—	—	S	281156	0.92
3/4	12	3,000	111	CIR-5122	—	—	—	281164	0.92
3/4	12	4,000	148	CIR-5124	—	—	S	244582	0.92
3/4	13-3/8	650	21	CIR-5135	NS	140337	S	275864	1.02
3/4	13-3/8	2,500	83	CIR-5134	—	—	S	278150	1.02
3/4	14	1,250	40	CIR-5141	—	—	—	244590	1.07
3/4	14	2,500	80	CIR-5142	—	—	—	244603	1.07

Specifications and Ordering Information

DIM (In.)		Watts	W/in ²	Model	120V		240V		Wt. (Lbs.)
Dia.	Sheath Length				Stock	PCN	Stock	PCN	
3/4" Diameter									
3/4	14	4,500	142	CIR-5144	—	—	—	244611	1.07
3/4	14-7/8	750	22	CIR-5148	S	140345	S	275872	1.14
3/4	15	1,500	44	CIR-5150	—	—	—	281172	1.15
3/4	16	1,800	49	CIR-5162	—	—	—	244620	1.23
3/4	16	4,700	128	CIR-5165	—	—	—	244638	1.23
3/4	16-1/4	800	22	CIR-5163	—	—	S	140353	—
3/4	17-3/4	850	21	CIR-5177	—	—	NS	275880	1.36
3/4	18	1,500	36	CIR-5180	—	—	—	281180	1.38
3/4	18	2,000	48	CIR-5182	—	—	—	244646	1.38
3/4	18	5,000	122	CIR-5185	—	—	—	244654	1.38
3/4	20	1,000	22	CIR-5204	—	—	NS	140361	—
3/4	20	1,150	25	CIR-5202	—	—	—	244662	1.53
3/4	20	2,000	44	CIR-5201	—	—	—	281199	1.53
3/4	20	2,250	49	CIR-5203	—	—	—	244670	1.53
3/4	20	3,850	84	CIR-5200	—	—	S	278168	1.53
3/4	20	5,000	110	CIR-5205	—	—	—	244689	1.53
3/4	22	1,150	23	CIR-5220	—	—	S	140370	—
3/4	24	1,250	23	CIR-5241	—	—	S	275899	1.84
3/4	24	1,375	25	CIR-5243	—	—	—	244697	1.84
3/4	24	2,500	42	CIR-5242	—	—	—	281201	1.84
3/4	24	2,750	50	CIR-5244	—	—	—	244700	1.84
3/4	24	4,600	83	CIR-5240	—	—	S	278176	1.84
3/4	24	5,000	85	CIR-5245	—	—	—	244718	1.84
3/4	30	2,500	37	CIR-5301	—	—	S	140388	—
3/4	30	4,800	69	CIR-5300	—	—	S	278184	2.3
3/4	36	2,500	30	CIR-5362	—	—	—	244726	2.75
3/4	36	4,900	59	CIR-5360	—	—	NS	278192	2.75
3/4	48	5,000	45	CIR-5480	—	—	S	278205	3.7

Stock Status: S = stock NS = non-stock
To Order—Specify model, PCN, watts, volts and quantity.

CARTRIDGE

C-DD

Deep Drawn Cartridge Heater

- **Seamless Sheath - No Welded End Disk**
- **304 or 316 Stainless Steel Sheath**
- **Electropolished (Option)**
- **Diameters Available:**
1/8", 1/4", 3/8", 1/2", 5/8", 3/4"
(.3175, .635, .9525, 1.27, 1.5875, 1.905 cm)
- **Lengths Up to 10" (25.4 cm). See Chart**
- **High Watt Densities Available**

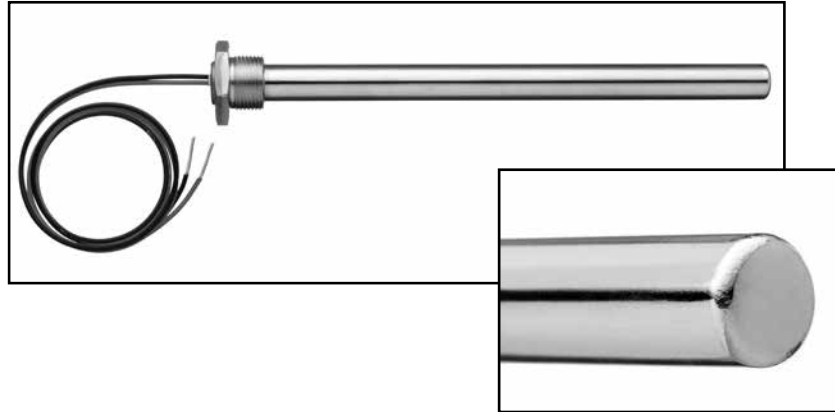

Advantages

Deep drawing is a sheet metal process where a sheet metal blank is radially formed into a forming die with a punch. Traditional cartridge heaters use "as welded" or "drawn over mandril" tube construction, using strip that is formed into a tube and welded. Deep drawing eliminates any weld seams that are typical on traditional cartridge heaters. Deep drawing also eliminates the need for a welded end disk which if improperly manufactured can cause the ingress of moisture into the element. This product is ideal for use in critical applications and anywhere risk mitigation is a concern.

Applications

Medical:

- Dialysis
- Nebulizers
- Hydrotherapy
- Pathology Analysis

Analytical:

- Chromatographs
- Water Baths
- Cleaners/Washers

Transportation:

- Potable Water Heaters
- Galley Equipment

Construction

C-DD uses the same robust construction as our standard high watt density cartridge heater. This model is typically supplied with a bushing or flange for immersion applications, but can also be supplied with any of the standard "CIR" configuration and seal options. Sheath material is available in either 304 or 316 stainless steel. The units can be passivated or electropolished for additional corrosion resistance.

Diameter In. (cm)	Maximum Length In. (cm)	Maximum Voltage
1/8 (.3175)	2.5 (6.35)	240
1/4 (.635)	3.75 (9.525)	240
3/8 (.9525)	5 (12.7)	480
1/2 (1.27)	7.5 (19.05)	480
5/8 (1.5875)	8 (20.32)	480
3/4 (1.905)	10 (25.4)	480



C-HD

Heavy Duty Cartridge Heater

- 1 and 1-19/64" Dia.
- 140 - 1,780 Watts
- 120 and 240 Volt
- 11 - 50 W/In²
- Brass Sheath
- Two Bolt Terminals, One End
- Up to 600°F Max. Working Temp.

Applications

- Aluminum Extraction Dies
- Container Heaters
- Large Platens
- Molds
- Dies
- Stress Relaxing

Construction

Type C-HD is a high quality cartridge heater for medium and low watt density applications.

Available in 15/16, 1 and 1-19/64" diameter, sheath lengths up to approximately 2 feet.

Dimensions

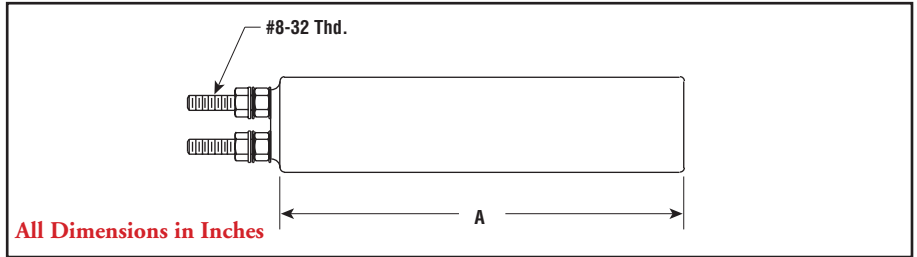

Specifications and Ordering Information

Dimensions (In.)		Watts	W/In ²	Model	120V		240V		Wt. (Lbs.)
Dia.	Sheath Length				Stock	PCN	Stock	PCN	
1	3-3/8	300	35	C-703	S	137920	S	137939	0.31
1	4-7/8	375	28	C-704	—	—	S	137955	0.5
1	6-3/8	600	33	C-705	NS	137963	S	137971	0.63
1	7-7/8	500	22	C-706	NS	137980	—	—	0.75
1	9-3/8	700	26	C-707	NS	138000	S	138018	0.75
1	10-7/8	750	23	C-708	—	—	NS	138034	1
1	12-3/8	800	22	C-709	—	—	S	138050	1.13
1	18-3/8	1,250	23	C-713	—	—	S	138077	1.75
1	3-1/8	165	21	C-702	NS	137904	NS	137912	0.31
1	4-7/8	375	28	C-704	NS	137947	—	—	0.5
1	4-7/8	500	28	C-706	—	—	NS	137998	0.5
1	10-7/8	750	23	C-708	NS	138026	—	—	1
1	12-3/8	800	22	C-709	NS	138042	—	—	1.13
1	18-3/8	1,250	23	C-713	NS	275944	—	—	1.75
1	21	1,300	21	C-714	—	—	NS	275987	2.1
1	23	1,425	20	C-715	—	—	NS	275995	2.2
1	25	1,375	18	C-716	—	—	NS	276007	2.25
1-19/64	3-1/2	350	33	C-803	NS	138288	NS	138296	0.5
1-19/64	4-7/8	600	37	C-806	S	138325	S	138333	0.75
1-19/64	7-5/8	1,000	37	C-830	NS	138384	NS	138392	1.25
1-19/64	7-5/8	1,200	44	C-810	NS	138405	S	138413	1.25
1-19/64	10-1/2	1,000	26	C-812	NS	138448	S	138456	1.75
1-19/64	4-7/8	300	19	C-804	NS	138317	NS	138309	0.75
1-19/64	6-1/4	500	23	C-807	NS	138341	NS	138350	1
1-19/64	7-5/8	500	18	C-808	NS	138368	NS	138376	1.25
1-19/64	9	650	20	C-811	NS	138421	NS	138430	1.5
1-19/64	11-7/8	750	17	C-813	NS	138464	NS	138472	2
1-19/64	14-5/8	1,250	22	C-815	NS	138480	NS	138499	2.25
1-19/64	16	1,300	21	C-816	NS	138501	NS	138510	2.75
1-19/64	17-1/2	1,400	20	C-817	—	—	NS	277085	3
1-19/64	20-1/4	1,625	20	C-819	—	—	NS	277093	3.5
1-19/64	24-1/2	1,780	18	C-822	—	—	NS	277106	3.75

Stock Status: S = stock NS = non-stock
To Order—Specify model, PCN, watts, volts and quantity.